

SECTION 5  
SCALE: 3/4"=1'-0"

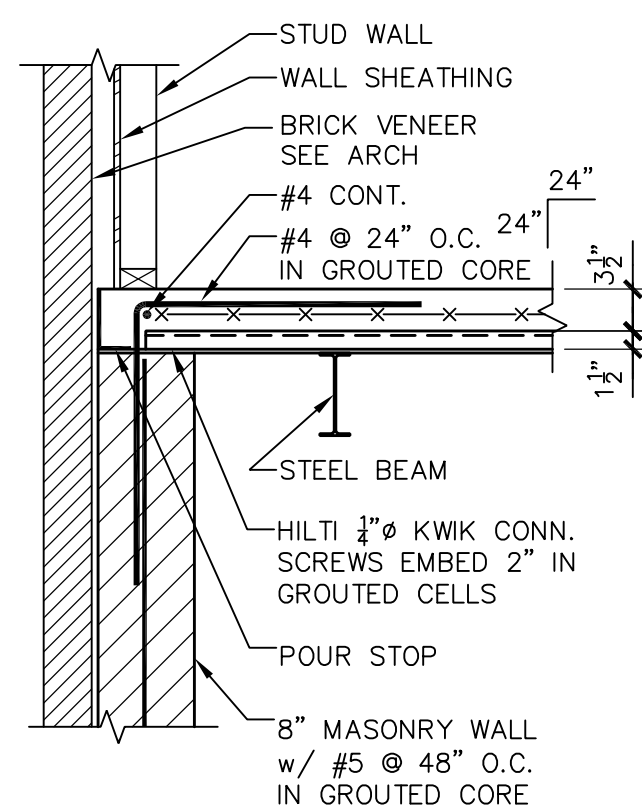

SECTION 4  
SCALE: 3/4"=1'-0"

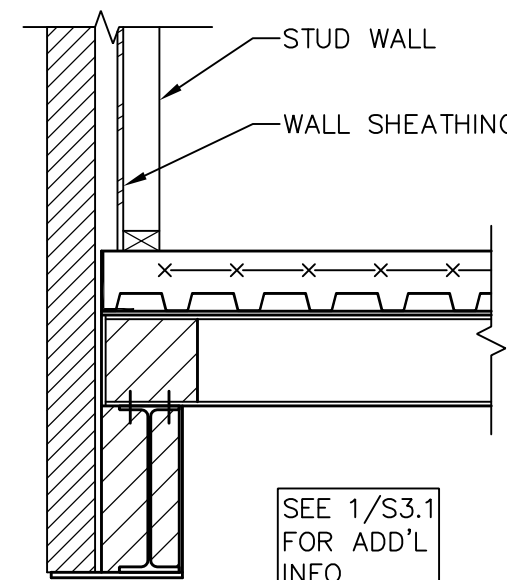

SECTION 3  
SCALE: 3/4"=1'-0"

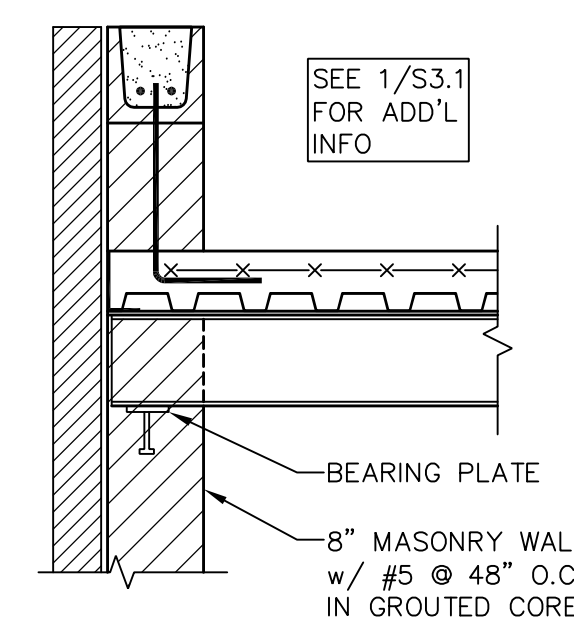

SECTION 2  
SCALE: 3/4"=1'-0"

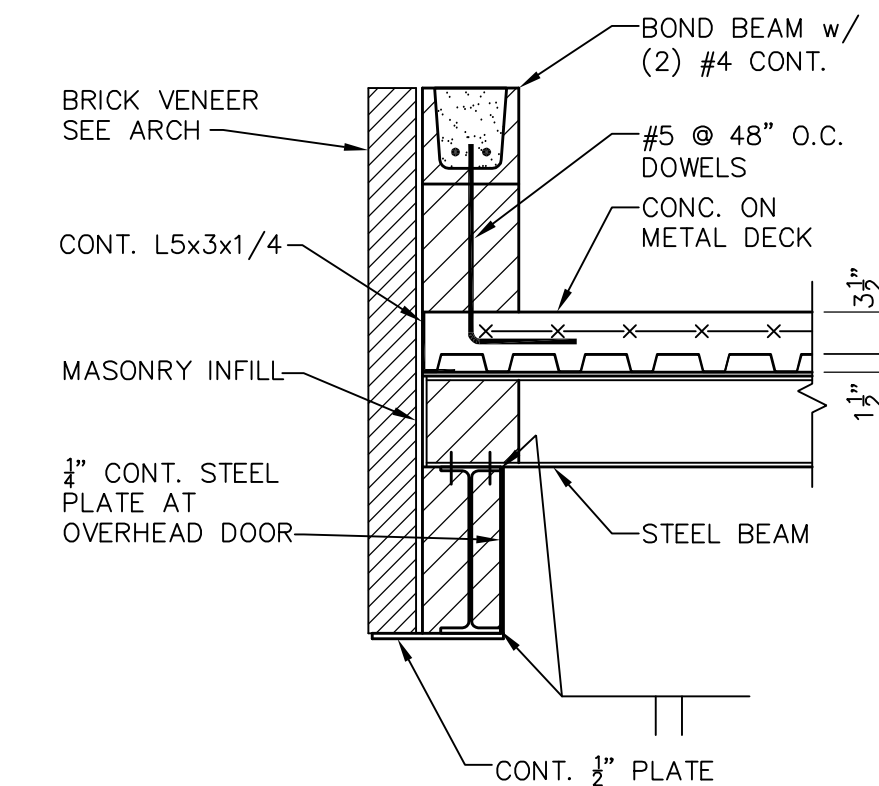

SECTION 1  
SCALE: 3/4"=1'-0"

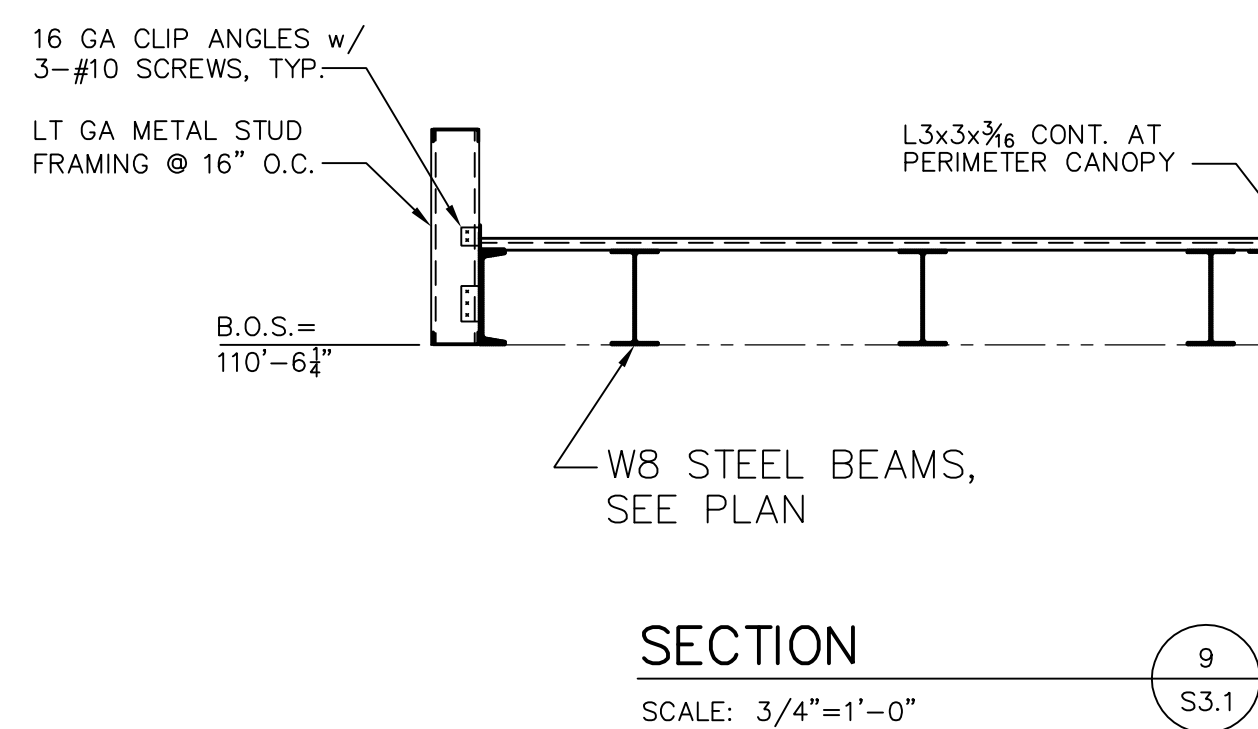

SECTION 9  
SCALE: 3/4"=1'-0"

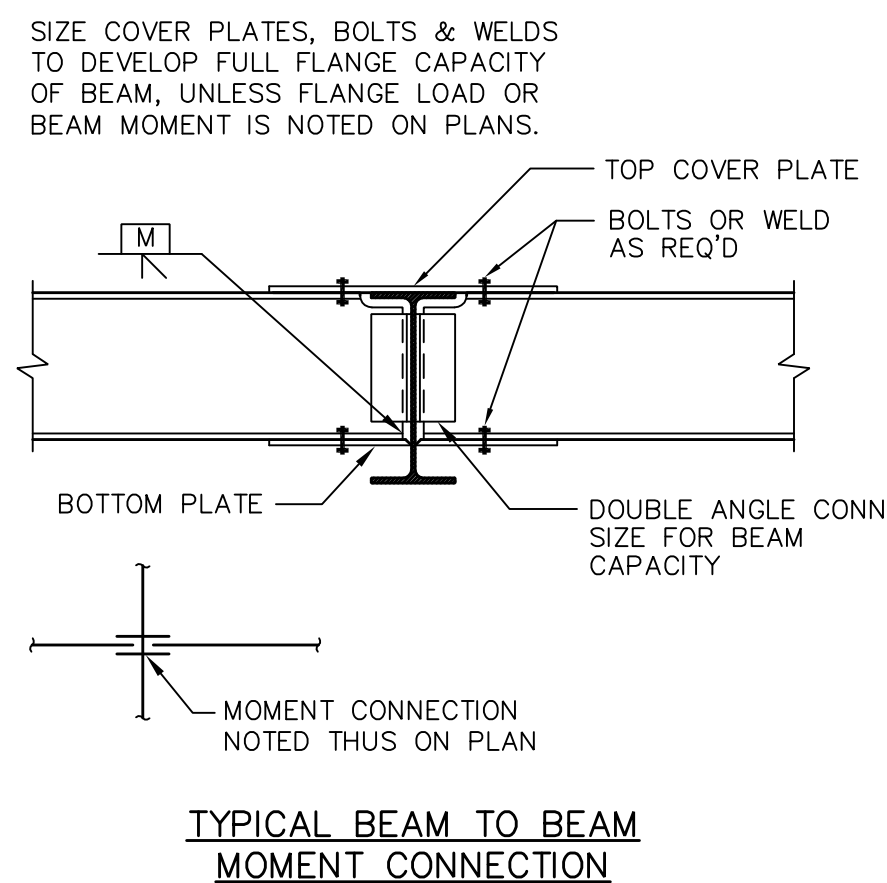
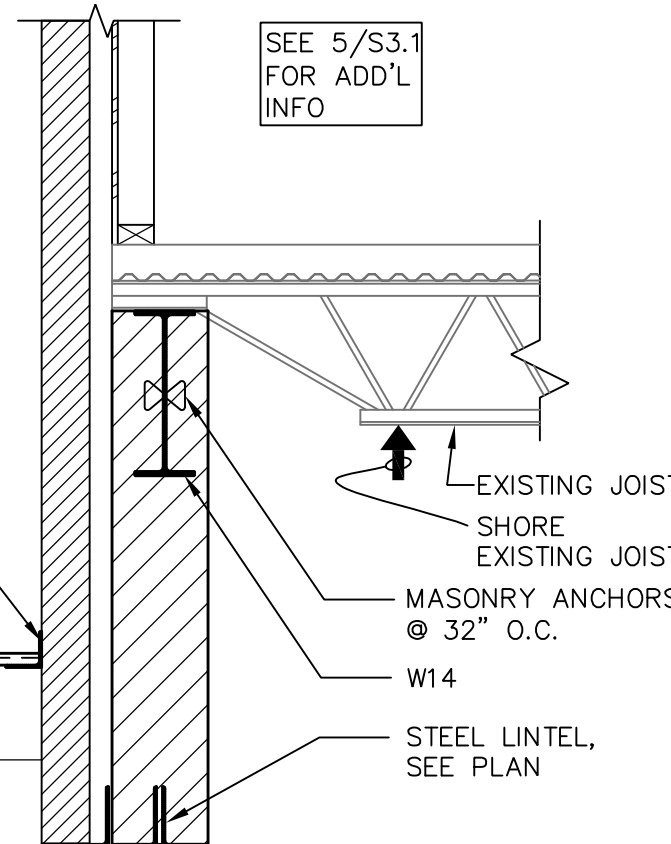

SECTION 8  
SCALE: 3/4"=1'-0"

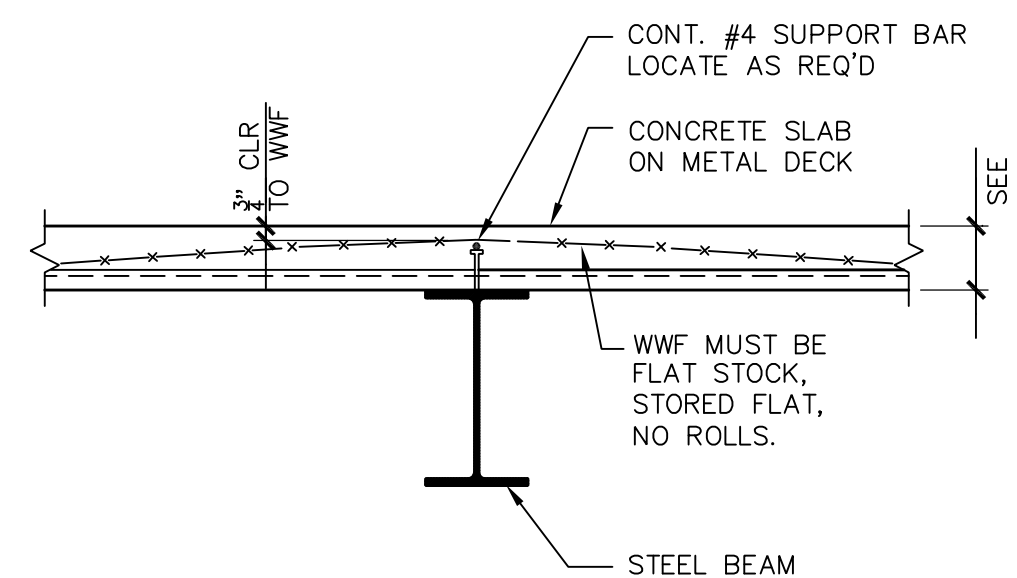

SECTION 7  
SCALE: 3/4"=1'-0"

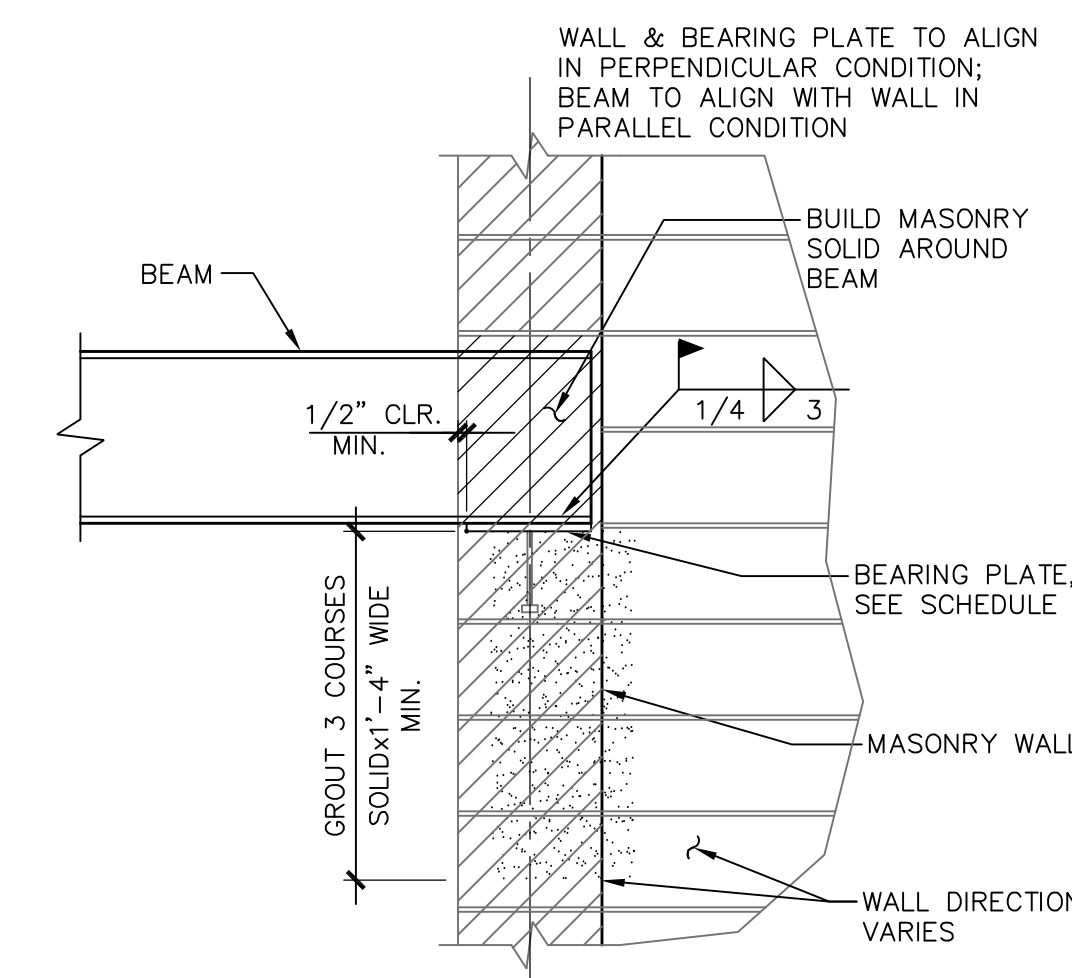

SECTION 6  
SCALE: 3/4"=1'-0"

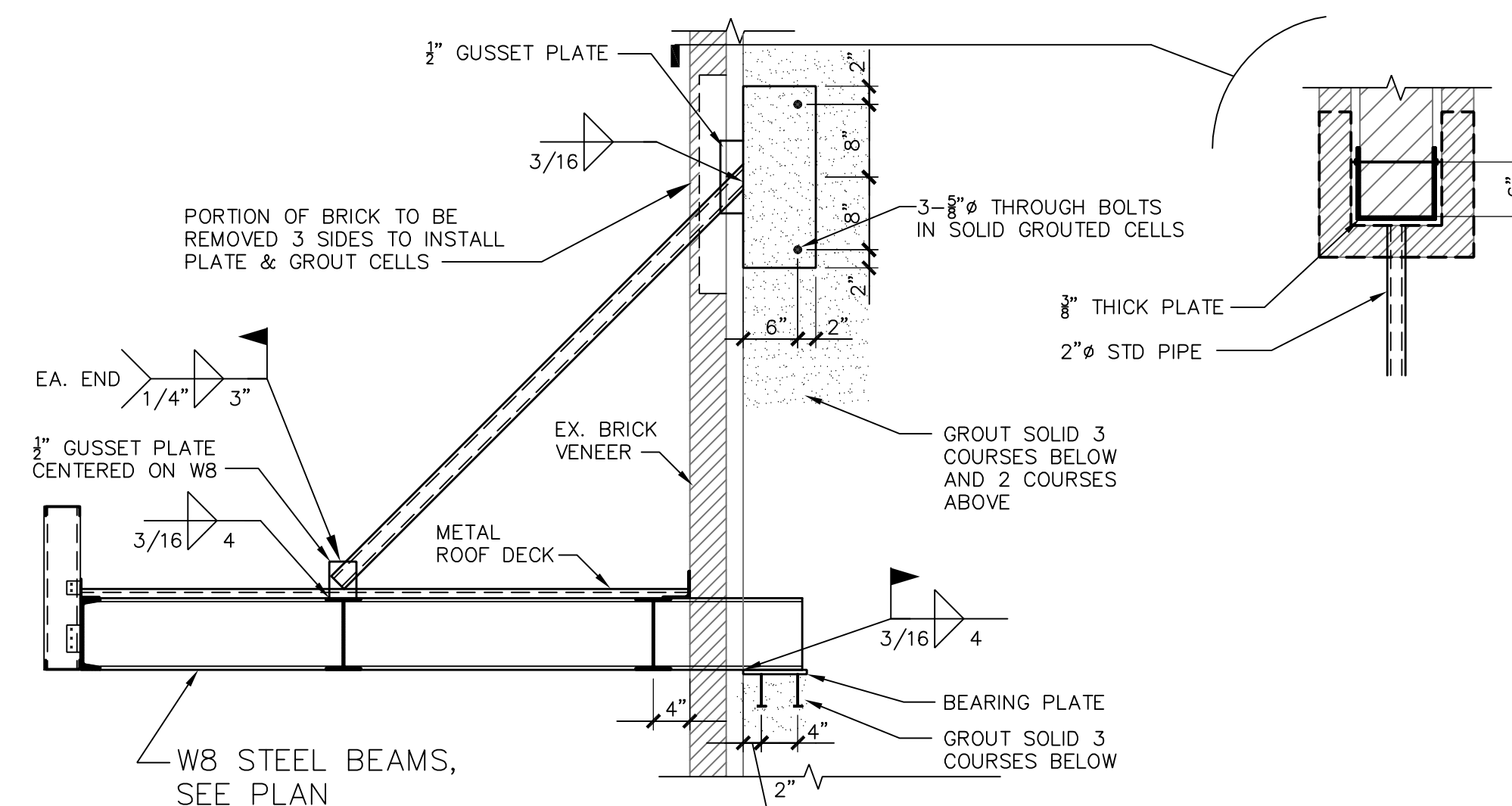

SECTION 10  
SCALE: 3/4"=1'-0"

THIS DRAWING & THE DESIGN SHOWN THEREON ARE THE PROPERTY OF ZVIC & HURDLE ARCHITECTS. THE REPRODUCTION, COPYING, OR USE OF THIS DRAWING W/O THEIR SPECIFIC WRITTEN CONSENT IS PROHIBITED & ANY INFRINGEMENT WILL BE SUBJECT TO LEGAL ACTION.

REVISION	DATE	DESCRIPTION
	09/30/2016	BID/PERMIT SUBMISSION
	07/20/2016	PERMIT SUBMISSION

DESIGNED BY: \_\_\_\_\_ CHECKED BY: \_\_\_\_\_  
DRAWN BY: \_\_\_\_\_ APPROVED BY: \_\_\_\_\_



**RESCUE 8 STATION**  
ALBEMARLE COUNTY, VA

3045 BERKMAR DR.  
CHARLOTTESVILL, VA  
ZHA PROJECT NUMBER: 15115.00



SHEET TITLE:  
**FRAMING SECTIONS**

SCALE:  
SHEET NO: **S3.1**

ISSUE DATE:

